



TJEP RE-BAR XP 40



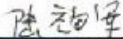

Declaration of conformity

We	Taizhou Xindalu Electronic Technology Co., Ltd. No. 167, Nanhuan RD, Wenling Zhejiang, China
declare under our sole responsibility that the	TJEP RE-BAR XP 25mm, 40mm and 58mm
conforms with the directive	Machine Directive 2006/42/EC Elektro Magnetic Comp. direc. 2004/108/EC
and the standards	EN 55014-1:2006/A2:2011 EN 55014-2:2015 EN 60745-1:2009/A11:2010 EN ISO 12100:2010
	Signed:  Mr. Fujun Lu, General manager
Authorized contact in EU to compile the Technical File:	KYOCERA UNIMERCO Fastening A/S Drejervej 2 DK-7451 Sunds Denmark

TJEP RE-BAR XP 40

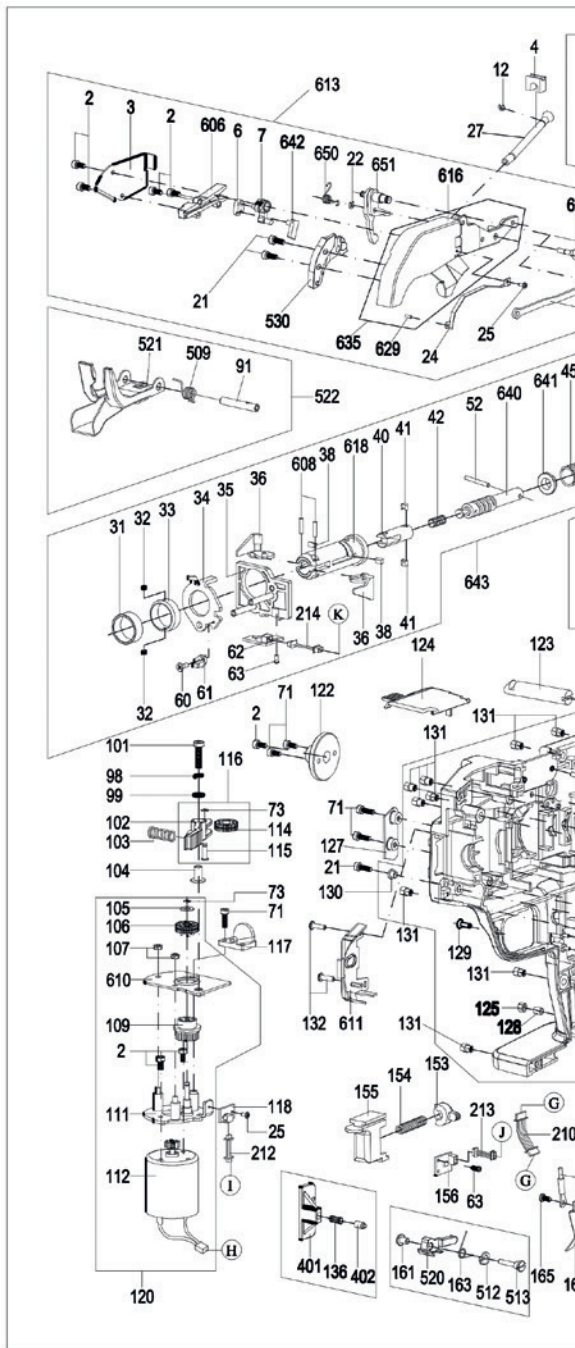

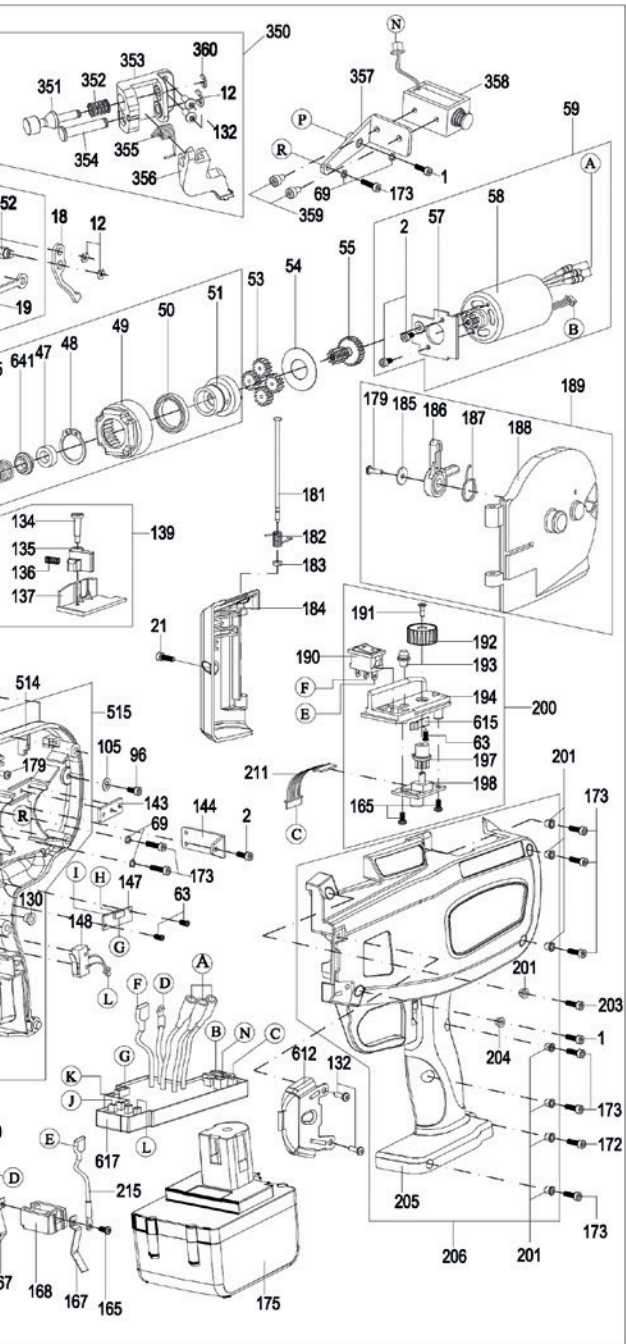

Spare parts

ITEM NO.	PART NO.	DESCRIPTION
1	11027	Hex Bolt M3×12
2	11034	Hex Bolt M3×6
3	11041	Arm A
4	11058	Rubber Base
606	11324	Wire Guide B
6	11072	Connecting Plate 1
7	11089	Cutter
530	11430	Wire Guide A
12	11133	E-Ring 4
616	11348	Arm A unit
18	11195	Cutter Lever C
19	11201	Connecting Rod 1
21	11225	Hex Bolt M3×10
22	11232	E-Ring 2.5
24	11256	Leaf Spring
25	11263	Pan-head Screw M2×4
613	11355	Arm A unit Assy
27	11270	Pipe
629	11386	Fixing Pin 2
31	13021	Sleeve Guide
32	13038	Hex Screw M3×4
33	13045	Cutting Ring Guide
34	13052	Cutting Plate
35	13069	Tip Axis Guide Assy
36	13076	Hook
608	13342	Spring Pin φ2.5
38	13090	Key A
618	13366	Sleeve A
40	13113	Tip Axis B
41	13120	Key B
42	13137	Comp. Spring 1
45	13168	Comp. Spring 2
47	13175	Bumper
48	13182	C-ring 20
49	13199	Internal Gear
50	13205	Bearing
51	13212	Planet Gauge Unit
52	13229	Pin 5
53	13236	Planet Gear
54	13243	Gear Press Wheel
55	13250	Sun Gear Unit
57	13274	Motor Fixing plate
58	13281	Motor 550-R2
59	13014	Motor 550-R2 Assy

ITEM NO.	PART NO.	DESCRIPTION
60	13298	Countersunk screw M2×4
61	13304	Magnetic Plate
62	13311	Route PWB Unit
63	13328	Pan-head Screw ST2.2×6
69	12178	Spring Washer φ3
71	12024	Hex Bolt M3×8
73	12048	E-Ring 2
350	12444	Brake Housing Assy
351	12451	Reel Press limit Axis
352	12468	Comp. Spring 7
353	12475	Reel Press D
354	12482	Reel Press Centre Axis
355	12499	Torsion Spring 7
356	12505	Reel Press A
357	12512	Solenoid Holder
358	12529	Solenoid
359	12536	Hex Bolt M3X4
360	12543	E-ring 3
521	11409	Curl Guide
509	11416	Torsion Spring 3
522	11423	Curl Guide Assy
91	11300	Stopper Shaft
96	17500	SS Hex Bolt M3x12
98	14219	Spring Washer φ4
99	14226	Washer 2
101	14240	Hex Bolt M4×16
102	14028	Release Lever
103	14035	Comp. Spring 3
104	14042	Hollow Pin 1
105	14058	Washer
106	14066	Feeding Gear B1
107	14073	Nut M3(T 2.4)
610	14233	Partition Plate
109	14097	Feeding Gear A
111	14110	Connecting Plate Unit
112	14127	Motor 540-R2
114	14141	Feeding Gear B2
115	14158	Step Pin 1
116	14165	Release Lever Assy
117	14172	Wire Guide C
118	14189	Feeding PWB unit
120	14004	Motor 540-R2 Assy
122	17029	Reel Guide
123	17036	Joint Reel Magazine

ITEM NO.	PART NO.	DESCRIPTION
124	17043	Window
125	17050	Nut M3 (T4)
127	17074	Strength Plate
128	17081	Hollow pin 6
129	17098	Cross head tapping screw ST2.2 × 7
130	17104	Hollow Pin 3
131	17111	Nut M3
132	17128	Hex Bolt M3×8
611	17494	Cover L Unit
134	17142	Step Pin 2
135	17159	Release Stopper
136	17166	Comp. Spring 4
137	17173	Reel Stopper
139	17180	Reel Stopper Assy
514	17654	Frame L
515	17692	Frame L Assy
143	17210	Fixing Plate 1
144	17227	Fixing Plate 2
147	17258	Motor 540-R2 PWB Unit
148	17265	Trigger Switch
153	17296	Trigger Lock
154	17302	Comp. Spring 5
155	17319	Trigger
156	17326	Sensor PWB D Unit
401	17623	Jaw
513	17562	Bolt
402	17630	Jaw Pin
161	17364	Pin 4
520	17579	Switch Lever
163	17388	Torsion Spring 4
512	17586	Switch Lever Connector
165	17401	Pan-head Screw ST3×8
167	17425	Electrode Plate
168	17432	Electrode Block
612	18095	Cover P Unit
172	17487	Hex Bolt M3×16
173	17449	Hex Bolt M3×14
617	18101T	Main PWB Unit
175	18033	Li-ion Battery
179	15018	Pan Head Screw M3×5
181	15032	Step Pin 3
182	15049	Torsion Spring 5
183	15056	Rubber Washer
184	15063	Motor Cover

ITEM NO.	PART NO.	DESCRIPTION
185	15070	Washer 3
186	15087	Reel Stopper
187	15094	Torsion Spring 6
188	15117	Real Stay
189	15124	Real Stay Assy
190	16015	Main Switch Unit
191	16022	Countersunk Scew M3×5
192	16138	Adjusting Knob
193	16046	LED Unit
194	16053	Adjusting Plate
615	16107	Adjusting Spring
197	16084	Joint Knob
198	16091	Adjusting PWB Unit
200	16121	Main Switch Base Assy
201	18040	Hollow Pin 7
203	18064	Hex Bolt M3×18
204	18071	Hollow Pin 5
205	18125	Frame R
206	18132	Frame R Assy
210	17456	Motor 540-R2 Connecting Wire
211	16114	Adjusting Connecting Wire
212	14202	Feeding Connecting Wire
213	17463	Sensor Connecting Wire
214	13335	Rotating Connecting Wire
215	17470	Battery Connecting Wire
635	11393	Arm A unit with Fixing Pin 2
640	13373	Tip Axis A
641	13380	Pin 1
642	11379	Fixed Cutter
643	13397	Twister Assy
650	11539	Torsion Spring 8
651	11546	Cutter Lever A+B
652	11553	Shaft Screw
653	11560	Cutter Lever A+B Assy



KYOCERA UNIMERCO Fastening A/S
Drejervej 2
DK-7451 Sunds
Tlf. +45 97 14 14 40
Fax +45 97 14 14 86
tjep@kyocera-unimerco.com

www.tjep.eu